

FK SERIES

FIXED SIDE

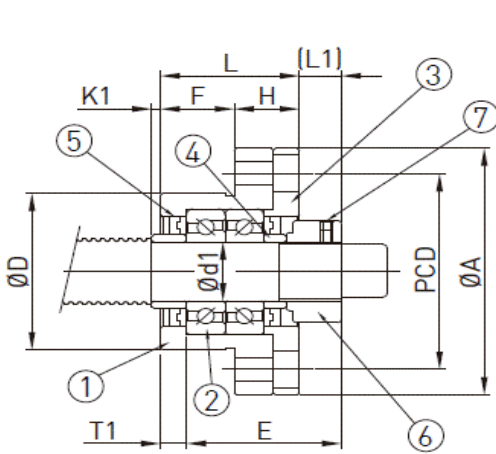

Mounting method A

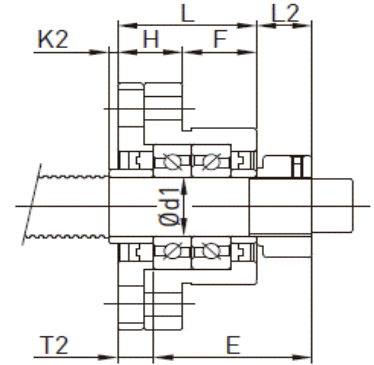
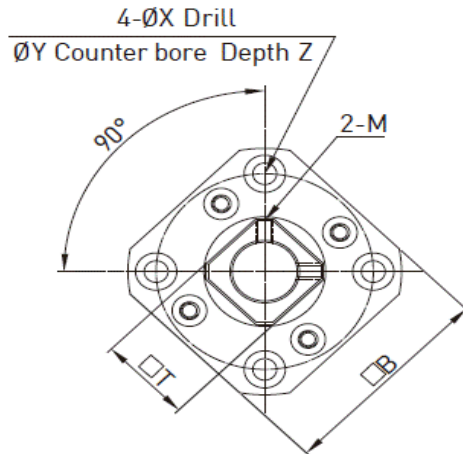

Mounting method B

Part	Part Name	Qty
1	Housing	1
2	Bearing	1 Set
3	Holding Lid	1
4	Collar	2
5	Seal	2
6	Set Screw	1
7	Hexagonal Socket-Head Setscrew with	2



Specification	Main Dimensions (mm)																				Weight (kg)
	d1	L	H	F	E	D (Note 1)	A	PCD	B	Mounting Method A			Mounting Method B			X	Y	Z	M	T	
										L1	T1	K1	L2	T2	K2						
FK05	5	16.5	6	10.5	18.5	20	34	26	26	5.5	3.5	0	5	3	0.5	3.4	6.5	4	M3	11	0.1
FK06	6	20	7	13	22	22	36	28	28	5.5	3.5	1.5	6.5	4.5	0.5	3.4	6.5	4	M3	12	0.1
FK08	8	23	9	14	26	28	43	35	35	7	4	1.5	8	5	0.5	3.4	6.5	4	M3	14	0.16
FK10	10	27	10	17	29.5	34	52	42	42	7.5	5	0.5	8.5	6		4.5	8	5	M3	16	0.25
FK12	12	27	10	17	29.5	36	54	44	44	7.5	5	0.5	8.5	6		4.5	8	5	M4	19	0.26
FK15	15	32	15	17	36	40	63	50	52	10	6	4	12	8	2	5.5	9.5	6	M4	22	0.4
FK17	17	45	22	23	47	50	77	62	61	11	9	1	14	12	-2	6.6	11	10	M4	24	0.85
FK20	20	52	22	30	50	57	85	70	68	8	10	1	12	14	-3	6.6	11	10	M4	30	1.2
FK25	25	57	27	30	60	63	98	80	79	13	10	5	20	17	-2	9	15	13	M6	35	1.6
FK30	30	62	30	32	61	75	117	95	93	11	12	-3	17	18	-9	11	17.5	15	M6	40	2.38